

Aztra Range

Model: 5UC, 5CT & 10CT - Datasheet

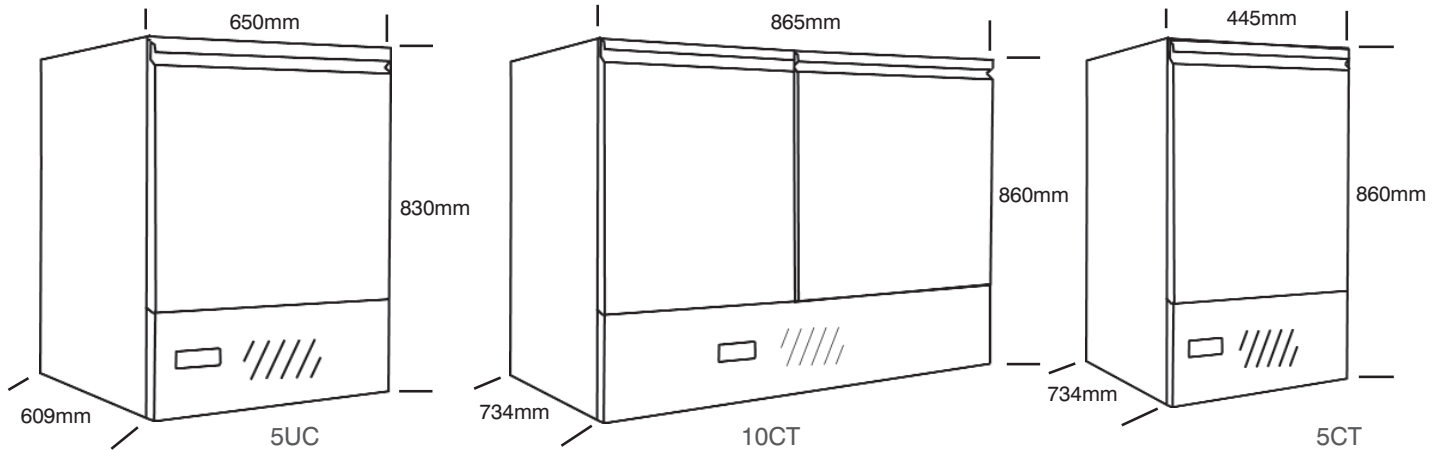

Key Features

- Foodsafe stainless steel exterior and interior base, with aluminium interior walls
- CoolSmart controller is designed for easy operation and features clear digital display
- Designed and engineered to operate efficiently up to a 43°C ambient, this exceeds Climate Class 5
- Integral 'easy grab' door handle - easy to clean with no potential dirt traps
- Self closing doors minimises temperature gain, reducing energy consumption
- Precision injected, high density 75mm polyurethane insulation. Provides excellent thermal efficiency with low GWP (Global Warming Potential) and zero ODP (Ozone Depletion Potential)
- Castors to rear, adjustable feet to front for cabinet stability

- Front vented commercial refrigeration system for excellent performance



Options

- Stainless steel interior
- Additional shelving / trayslides
- 2 drawers on high temp 5UC only
- Left door hang
- Hydrocarbon version on the 5UC

Variant	Temp	Storage
HAZ5UC	+1/+4°C	General Produce
LAZ5UC	-18/-22°C	Frozen Food
HAZ5CT	+1/+4°C	General Produce
LAZ5CT	-18/-22°C	Frozen Food
HAZ10CT	+1/+4°C	General Produce
LAZ10CT	-18/-22°C	Frozen Food

Dimensions

	HAZ5UC	LAZ5UC	HAZ5CT	LAZ5CT	HAZ10CT	LAZ10CT
External (mm):	H830 W650 D609	H830 W650 D609	H860 W445 D734	H860 W445 D734	H860 W865 D734	H860 W865 D734
Internal (mm):	H465 W580 D388	H465 W580 D388	H460 W376 D460	H460 W376 D460	H460 W360 per section D528	H460 W360 per section D528
Door Opening (mm):	D1200	D1200	D1125	D1125	D1110	D1110
Packed:	H1000 W800 D700	H1000 W800 D700	H965 W550 D830	H965 W550 D830	H965 W965 D830	H965 W965 D830
Weight: Add 5kg per product for packaging	54kg	62kg	55kg	61kg	75kg	81kg

Important Information

	HAZ5UC	LAZ5UC	HAZ5CT	LAZ5CT	HAZ10CT	LAZ10CT
Capacity: cu.ft/litres	5 / 141	5 / 141	5 / 141	5 / 141	10 / 283	10 / 283
Construction						
Exterior	0.7mm stainless steel	0.7mm stainless steel	0.7mm stainless steel	0.7mm stainless steel	0.7mm stainless steel	0.7mm stainless steel
Interior	0.7mm aluminium 0.6mm stainless steel liner base	0.7mm aluminium 0.6mm stainless steel liner base	0.7mm aluminium 0.6mm stainless steel liner base	0.7mm aluminium 0.6mm stainless steel liner base	0.7mm aluminium 0.6mm stainless steel liner base	0.7mm aluminium 0.6mm stainless steel liner base
Door	0.7mm stainless steel ext. 0.6mm stainless steel backclad	0.7mm stainless steel ext. 0.6mm stainless steel backclad	0.7mm stainless steel ext. 0.6mm stainless steel backclad	0.7mm stainless steel ext. 0.6mm stainless steel backclad	0.7mm stainless steel ext. 0.6mm stainless steel backclad	0.7mm stainless steel ext. 0.6mm stainless steel backclad
Power Supply	220V/240V 50Hz/1Ph 13 amp plug	220V/240V 50Hz/1Ph 13 amp plug	220V/240V 50Hz/1Ph 13 amp plug	220V/240V 50Hz/1Ph 13 amp plug	220V/240V 50Hz/1Ph 13 amp plug	220V/240V 50Hz/1Ph 13 amp plug
Power Input						
Start Up	8 amps	17.3 amps	8 amps	17.3 amps	10.3 amps	17.3 amps
Running	2 amps	2 amps	2 amps	2 amps	2.5 amps	2.5 amps
Compressor HP	1/5	1/2	1/5	1/2	1/4	1/2
Energy Consumption (Tested to EN153) in 24hrs	1.1kW	3.9kW	1.1kW	3.9kW	2.6kW	5kW
Heat Rejection (Evaporating at -10°C in 32°C ambient)	330watts	1009watts	330watts	1009watts	505watts	1009watts
Refrigerant	R134a	R404a	R134a	R404a	R134a	R404a
Defrost	Auto off- cycle	Auto hot gas Door mullion heaters	Auto off- cycle	Auto hot gas Door mullion heaters	Auto off- cycle	Auto hot gas Door mullion heaters
Insulation ODP Zero Polyurethane	50mm	50mm	75mm	75mm	75mm	75mm
Noise Output	59.0dBA	61.5dBA	59.0dBA	61.5dBA	61.0dBA	62.7dBA
Fittings						
Shelves	2 x 1/1GN (W325xD530)	2 x 1/1GN (W325xD530)	2 x 1/1GN (W325xD530)	2 x 1/1GN (W325xD530)	4 x 1/1GN (W325xD530)	4 x 1/1GN (W325xD530)



Bryggen Road, North Lynn Industrial Estate
King's Lynn, Norfolk PE30 2HZ
T +44 (0) 1553 817000
F +44 (0) 1553 817111
Spares +44 (0)1553 817017
E info@williams-refrigeration.co.uk
W www.williams-refrigeration.com