



**HV-100E and ZEPHAIRE-200-E**  
Hydrovection Stacked on a Full-Size Electric Convection Oven



Project \_\_\_\_\_

Item No. \_\_\_\_\_

Quantity \_\_\_\_\_

Requires Blodgett stacking kit #59260.

This model consists of a standard HV-100E stacked on a standard Zephaire-200-E. For more information on each oven refer to the the HV-100E and Zephaire-200-E specifications sheets.

**SHORT FORM SPECIFICATIONS** Provide Blodgett model HV-100E Hydrovection stacked on a model ZEPHAIRE-200-E full-size electric convection oven.

**HV-100E Hydrovection** - Shall have fully welded 304 stainless steel liner. Liner to be coved top and bottom. Unit shall accept five 18" x 26" standard full-size bake pans. Doors shall be triple mounted, black glass with dual pane thermal glass windows, curved handle and simultaneous operation. Unit shall be electrically heated by six tubular heaters. Air in baking chamber distributed by single inlet blower wheel powered by a four speed, auto-reversing, 3/4 HP motor with thermal overload protection. Each chamber shall be fitted with bright halogen lamps, and five standard stainless steel removable racks. Unit shall have programmable manual control capable of storing 100 recipes. Control shall feature incremental moisture control, hot air, cool down modes, core probe cook & hold and USB connection. Breaker shut off switch on front panel for easy service. 1 year parts and 1 year labor warranty.

**Zephaire-200-E** - Shall have porcelainized steel liner and shall accept five 18" x 26" standard full-size bake pans in left-to-right or front-to-back positions. Doors shall have dual pane thermal glass windows with single porcelain handle and simultaneous operation. Unit shall be electrically heated with three tubular heaters. Air in baking chamber distributed by single inlet blower wheel powered by a two-speed, 1/3 HP motor with thermal overload protection. Each chamber shall be fitted with five chrome-plated removable racks. Control panel shall be recessed with Cook/Cool Down mode selector, solid state manual infinite thermostat (200 - 500°F), and 60-minute timer. 1 year parts and 1 year labor, three year limited door warranty.

**SHIPPING INFORMATION:**

**Approximate Weight:**

HV-100E 450 lbs. (204 kg)

Zephaire-200-E 545 lbs. (247 kg)

**Crate size:**

Each section 37-1/2" (952mm) x 43-1/2" (1105mm) x 52" (1321mm)

**HV-100E STACKED ON A ZEPHAIRE-200-E**

**BLODGETT OVEN COMPANY**

www.blodgett.com

42 Allen Martin Drive, Essex Junction, VT 05452 • Phone: (802) 658-6600 • Fax: (802) 864-0183



# HV-100E STACKED ON A ZEPHAIRE-200-E

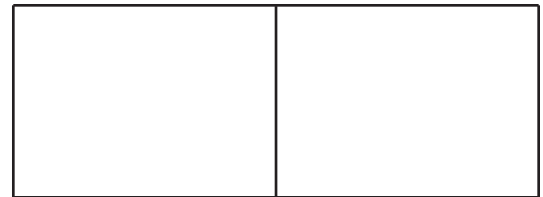

APPROVAL/STAMP

DIMENSIONS ARE IN INCHES (MM)

E Electric    V Vent  
W Water    D Drain

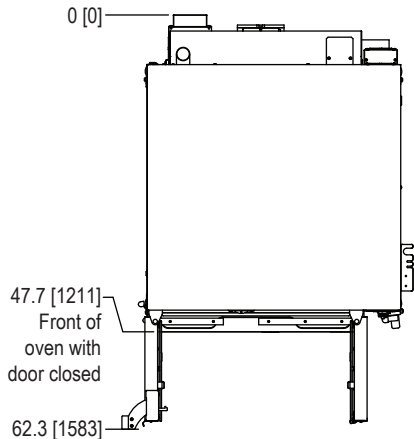

FRONT VIEW

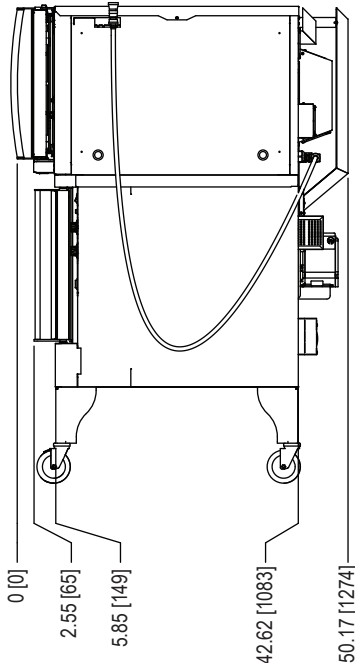

SIDE VIEW

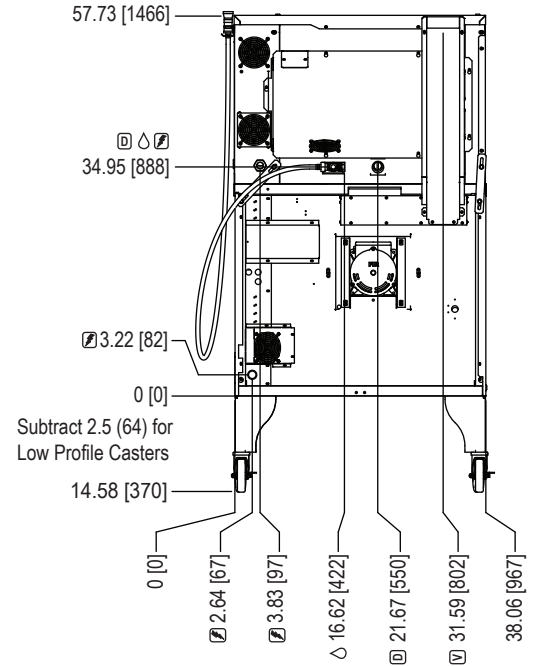

REAR VIEW

## DIMENSIONS:

### Product Clearance:

Oven sides 1/2" (13mm) Blodgett recommends 4" clearance from any heat source on the control panel side of the oven, an optional heat shield should be considered

Oven back 6" (152mm)

## POWER SUPPLY - ZEPHAIRE-200-E

V.A.C.	Hz	Phase	kW	Amperes (L1-L2-L3)
208	60.	1	11	51/0/51
208	60	3	11	31/29/29
220/240	60	1	11	44/0/44
220/240	60	3	11	26/24/24
440	60	3	11	15/14/14
480	60	3	11	14/13/13

1/3 HP, 2 speed motor, 1140 & 1725 rpm (60 Hz)

## POWER SUPPLY - HV-100E:

V.A.C.	Hz	Phase	kW	Amperes (L1-L2-L3)
208	60	3	15	38/38/38
240	60	3	15	36/34/34
440	60	3	15	20/18/18
480	60	3	15	18/17/17

3/4 H.P., 3 phase motor

## WATER & DRAIN CONNECTION - HV-100E:

**Drain** 1.25" OD drain connection  
Maximum drain temperature 140°F (60°C)

**Water** 3/4" NPT garden hose - cold water only  
The drain piping must consist of temperature resistant material, greater than 160°F, and be of adequate diameter not to cause flow restriction. Improper materials may deform and cause restrictions, thus affecting performance.

Appliance is to be installed with backflow protection in accordance with Federal, State or Local codes.

## WATER SUPPLY - HV-100E:

Good quality water feed is the responsibility of the owner. Water quality must be within the following general guidelines.

TDS: 40-125 ppm    Hardness: 35-100 ppm    pH: 7.0 - 8.5  
Silica: <13 ppm    Chlorides: <25 ppm    Chlorine: <0.2 ppm  
Chloramine: <0.2 ppm

The best defense against poor water quality is a water treatment system designed to meet your water quality conditions. Blodgett offers optional systems from Optipure.

**Water Pressure** 30(min)-50(max) PSI  
**Water Consumption** 2.5 - 4.0 GPH based on cooking mode

**NOTE:** The company reserves the right to make substitutions of components without prior notice

## BLODGETT OVEN COMPANY

www.blodgett.com 42 Allen Martin Drive, Essex Junction, VT 05452 • Phone: (802) 658-6600 • Fax: (802) 864-0183