

Emerald Range

Model: E2 & E3 - Datasheet

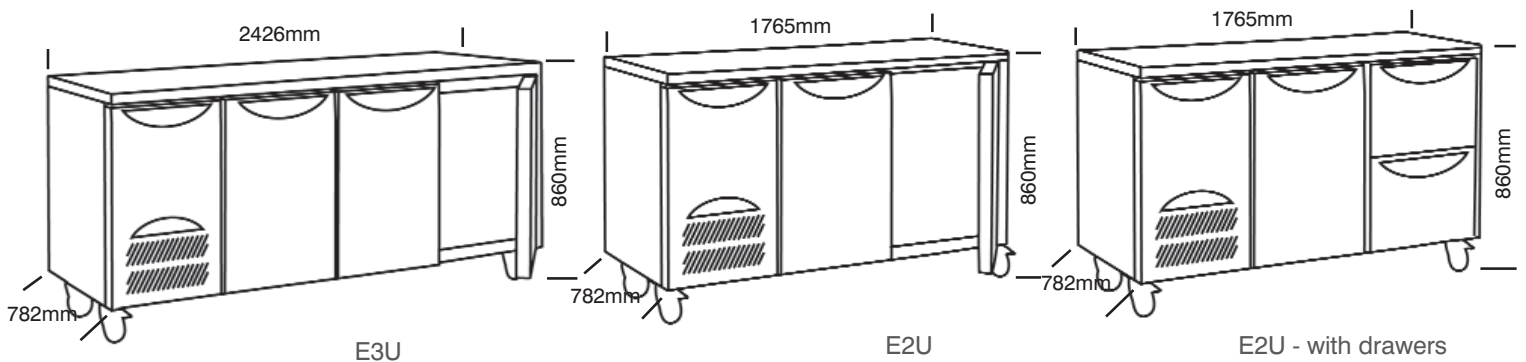

Key Features
<ul style="list-style-type: none"> • Foodsafe stainless steel exterior and interior • Radiused, easy clean, interior base corners to reduce potential dirt traps • CoolSmart controller is designed for easy operation and features clear digital display • Designed and engineered to operate efficiently up to a 43°C ambient, this exceeds Climate Class 5 • Self closing doors minimises temperature gain, reducing energy consumption • Precision injected, high density 75mm polyurethane insulation. Provides excellent thermal efficiency with low GWP (Global Warming Potential) and zero ODP (Ozone Depletion Potential) • Heavy duty, non-marking swivel castors with brakes – designed to fit through a standard door for ease of positioning • Barrel locked doors for added security

<ul style="list-style-type: none"> • Removable refrigeration cassette system for easy servicing • Anti-tilt, stain resistant coated shelving • Audio and visual hi/lo temp alarm • Condensor cleaning light to indicate when cleaning required to ensure effective performance • Defrost water is vaporized using recycled heat from compressor
--

Variant	Temp	Storage
HE2U	+1/+4°C	General Produce
ME2U	-2/+2°C	Meat
LE2U	-18/-22°C	Frozen Food
HE3U	+1/+4°C	General Produce
ME3U	-2/+2°C	Meat

Options
<ul style="list-style-type: none"> • Drawer banks (2 or 3) • Glass Doors • Pass through • Additional shelving / trayslides • Raised pan holder • Screw on splash-back • Hinged cover • Stainless steel back • Reverse unit • Wells - full / standard / special • Adjustable legs in lieu of castors (add 10mm) • Hydrocarbon version available • Glycol Secondary System • Remote applications

Dimensions

	HE2U	ME2U	LE2U	HE3U	ME3U
External (mm):	H860 W1765 D782	H860 W1765 D782	H860 W1765 D782	H860 W2426 D782	H860 W2426 D782
Internal (mm): w= per section	H600 W587 D683	H600 W587 D683	H600 W587 D683	H600 W587 D683	H600 W587 D683
Door Opening (mm):	D1410	D1410	D1410	D1410	D1410
Packed:	H950 W1815 D800	H950 W1815 D800	H950 W1815 D800	H950 W2475 D800	H950 W2475 D800
Weight: Add 5kg per product for packaging	167kg	145kg	160kg	198kg	210kg

Important Information

	HE2U	ME2U	LE2U	HE3U	ME3U
Capacity: cu.ft/litres	20.2 / 573	20.2 / 573	20.2 / 573	32 / 906	32 / 906
Construction					
Exterior	0.7mm stainless steel	0.7mm stainless steel	0.7mm stainless steel	0.7mm stainless steel	0.7mm stainless steel
Interior	0.7mm stainless steel	0.7mm stainless steel	0.7mm stainless steel	0.7mm stainless steel	0.7mm stainless steel
Door	0.7mm stainless steel	0.7mm stainless steel	0.7mm stainless steel	0.7mm stainless steel	0.7mm stainless steel
Power Supply	220V/240V 50Hz/1Ph 13 amp plug	220V/240V 50Hz/1Ph 13 amp plug	220V/240V 50Hz/1Ph 13 amp plug	220V/240V 50Hz/1Ph 13 amp plug	220V/240V 50Hz/1Ph 13 amp plug
Power Input					
Start Up	10.4 amps	10.4 amps	22 amps	17 amps	17 amps
Running	3 amps	3 amps	4 amps	3.5 amps	3.5 amps
Compressor HP	1/4	1/4	1/2	1/3	1/3
Energy Consumption (Tested to EN153) in 24hrs	3.2kW	4.3kW	10.2kW	4.4kW	5.3kW
Heat Rejection (Evaporating at -10°C in 32°C ambient)	507watts	665watts	1230 watts	665 watts	665watts
Refrigerant	R134a	R134a	R404a	R134a	R134a
Defrost	Auto off-cycle	Auto electric Door mullion heaters	Auto electric Door mullion heaters	Auto off-cycle	Auto electric Door mullion heaters
Insulation ODP Zero Polyurethane	75mm	75mm	75mm	75mm	75mm
Noise Output	51.0 dBA	51.0 dBA	52.0 dBA	51.0 dBA	51.0 dBA
Fittings					
Shelves (W530xD650) 2 X 1GN	4	4	4	6	6
Trayslides	8	8	8	12	12



Bryggen Road, North Lynn Industrial Estate
King's Lynn, Norfolk PE30 2HZ

T +44 (0) 1553 817000

F +44 (0) 1553 817111

Spares +44 (0)1553 817017

E info@williams-refrigeration.co.uk

W www.williams-refrigeration.com

All refrigeration equipment requires adequate ventilation for efficient and effective performance. Williams are committed to a policy continuing product development and innovation and as such, we reserve the right to change product specifications stated without prior notice.